

### BC546 / BC547 / BC548 TRANSISTOR (NPN)

#### FEATURES

- High Voltage
- Complement to BC556,BC557,BC558

#### MARKING

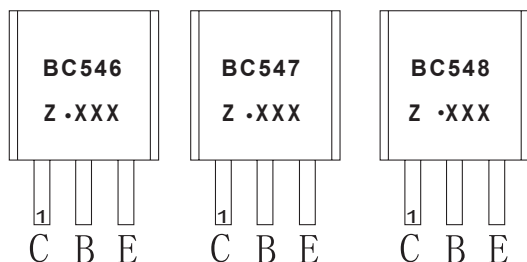

BC546,BC547,BC548=Device code

Solid dot=Green molding compound device, if none,the normal device

Z=Rank of  $h_{FE}$

XXX=Code

#### TO-92

1. COLLECTOR
2. BASE
3. EMITTER

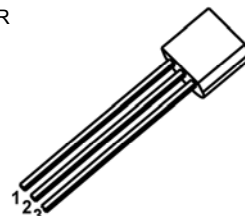

#### Equivalent Circuit

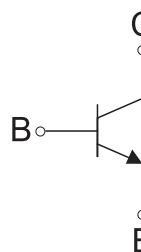

#### ORDERING INFORMATION

Part Number	Package	Packing Method	Pack Quantity
BC546	TO-92	Bulk	1000pcs/Bag
BC546-TA	TO-92	Tape	2000pcs/Box
BC547	TO-92	Bulk	1000pcs/Bag
BC547-TA	TO-92	Tape	2000pcs/Box
BC548	TO-92	Bulk	1000pcs/Bag
BC548-TA	TO-92	Tape	2000pcs/Box

#### MAXIMUM RATINGS ( $T_a=25^{\circ}\text{C}$ unless otherwise noted)

Symbol	Parameter	Value	Unit
$V_{CBO}$	Collector-Base Voltage	BC546	80
		BC547	50
		BC548	30
$V_{CEO}$	Collector-Emitter Voltage	BC546	65
		BC547	45
		BC548	30
$V_{EBO}$	Emitter-Base Voltage	BC546	6
		BC547	6
		BC548	5
$I_C$	Collector Current-Continuous	0.1	A
$P_C$	Collector Power Dissipation	625	mW
$R_{\theta JA}$	Thermal Resistance from Junction to Ambient	200	$^{\circ}\text{C}/\text{W}$
$T_j$	Junction Temperature	150	$^{\circ}\text{C}$
$T_{stg}$	Storage Temperature	-55~+150	$^{\circ}\text{C}$

### ELECTRICAL CHARACTERISTICS

$T_a=25\text{ }^\circ\text{C}$  unless otherwise specified

#### ELECTRICAL CHARACTERISTICS ( $T_a=25\text{ }^\circ\text{C}$ unless otherwise specified)

Parameter	Symbol	Test conditions	Min	Typ	Max	Unit
Collector-base breakdown voltage	BC546	$I_C=0.1\text{mA}, I_E=0$	80			V
	BC547		50			
	BC548		30			
Collector-emitter breakdown voltage	BC546	$I_C=1\text{mA}, I_B=0$	65			V
	BC547		45			
	BC548		30			
Emitter-base breakdown voltage	BC546	$I_E=10\mu\text{A}, I_C=0$	6			V
	BC547		6			
	BC548		5			
Collector cut-off current	BC546	$V_{CB}=70\text{V}, I_E=0$			0.1	$\mu\text{A}$
	BC547	$V_{CB}=50\text{V}, I_E=0$			0.1	$\mu\text{A}$
	BC548	$V_{CB}=30\text{V}, I_E=0$			0.1	$\mu\text{A}$
Collector cut-off current	BC546	$V_{CE}=60\text{V}, I_B=0$			0.1	$\mu\text{A}$
	BC547	$V_{CE}=45\text{V}, I_B=0$			0.1	$\mu\text{A}$
	BC548	$V_{CE}=30\text{V}, I_B=0$			0.1	$\mu\text{A}$
Emitter cut-off current	$I_{EBO}$	$V_{EB}=5\text{V}, I_C=0$			0.1	$\mu\text{A}$
DC current gain	$h_{FE}^*$	$V_{CE}=5\text{V}, I_C=2\text{mA}$	110		800	
Collector-emitter saturation voltage	$V_{CE(sat)}$	$I_C=100\text{mA}, I_B=5\text{mA}$			0.3	V
Base-emitter saturation voltage	$V_{BE(sat)}$	$I_C=100\text{mA}, I_B=5\text{mA}$			1.1	V
Base-emitter voltage	$V_{BE}$	$V_{CE}=5\text{V}, I_C=2\text{mA}$	0.58		0.7	V
		$V_{CE}=5\text{V}, I_C=10\text{mA}$			0.75	V
Collector output capacitance	$C_{ob}$	$V_{CB}=10\text{V}, I_E=0, f=1\text{MHz}$			4.5	pF
Transition frequency	$f_T$	$V_{CE}=5\text{V}, I_C=10\text{mA}, f=100\text{MHz}$	150			MH

#### CLASSIFICATION of $h_{FE}$

RANK	A	B	C
RANGE	110-220	200-450	420-800

**TO-92 Package Outline Dimensions**

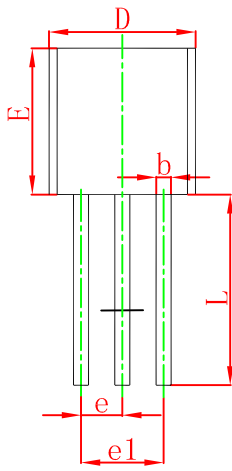
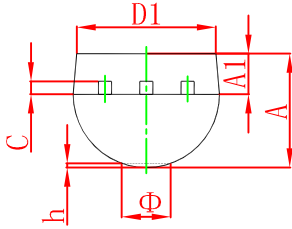

Symbol	Dimensions In Millimeters		Dimensions In Inches	
	Min	Max	Min	Max
A	3.300	3.700	0.130	0.146
A1	1.100	1.400	0.043	0.055
b	0.380	0.550	0.015	0.022
c	0.360	0.510	0.014	0.020
D	4.300	4.700	0.169	0.185
D1	3.430		0.135	
E	4.300	4.700	0.169	0.185
e	1.270 TYP		0.050 TYP	
e1	2.440	2.640	0.096	0.104
L	14.100	14.500	0.555	0.571
Φ		1.600		0.063
h	0.000	0.380	0.000	0.015

**TO-92 Suggested Pad Layout**

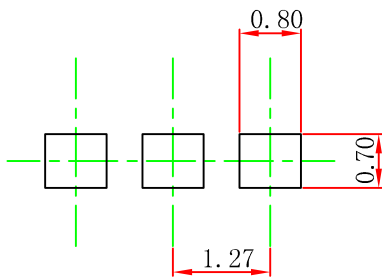

**Note:**

1. Controlling dimension: in millimeters.
2. General tolerance: ± 0.05mm.
3. The pad layout is for reference purposes only.

### TO-92 Tape and Reel

#### TO-92 PACKAGE TAPING DIMENSION

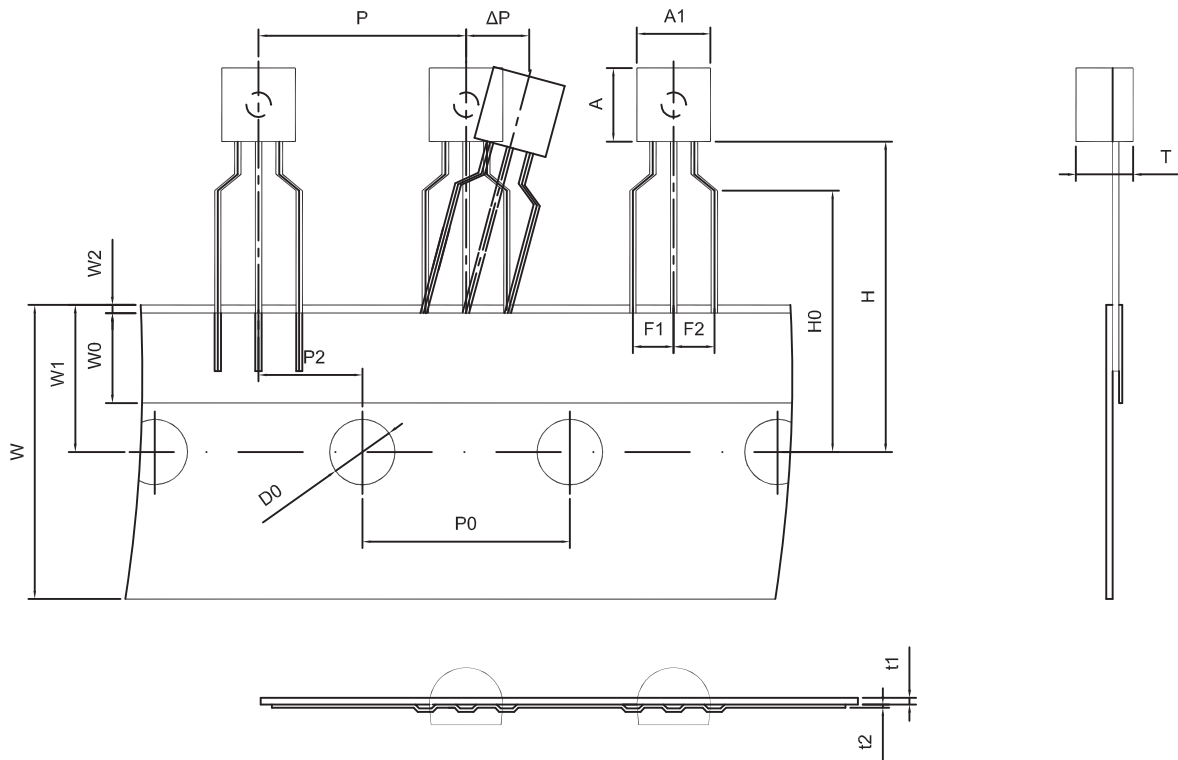

Dimensions are in millimeter

A1	A	T	P	P0	P2	F1	F2	W
4.5	4.5	3.5	12.7	12.7	6.35	2.5	2.5	18.0
W0	W1	W2	H	H0	D0	t1	t2	ΔP
6.0	9.0	1.0 MAX.	19.0	16.0	4.0	0.4	0.2	0

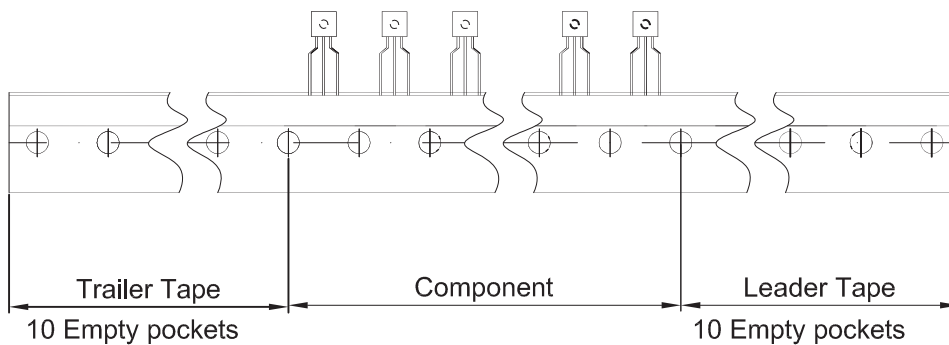

Package	Box	Box Size(mm)	Carton	Carton Size(mm)
TO-92	2000 pcs	333×162×43	20,000 pcs	350×340×250